

Technical Data

Specifications & Capacities

RTC 8050

Series II
Telescopic Boom Rough Terrain Crane
50 ton (45.35 metric ton)

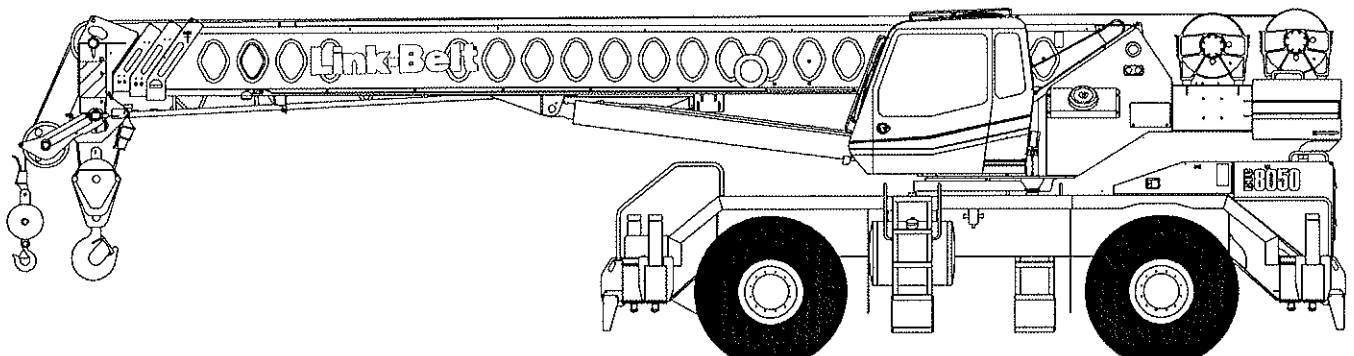

CAUTION: This material is supplied for reference use only. Operator must refer to in-cab Crane Rating Manual and Operator's Manual to determine allowable crane lifting capacities and assembly and operating procedures.

General Dimensions

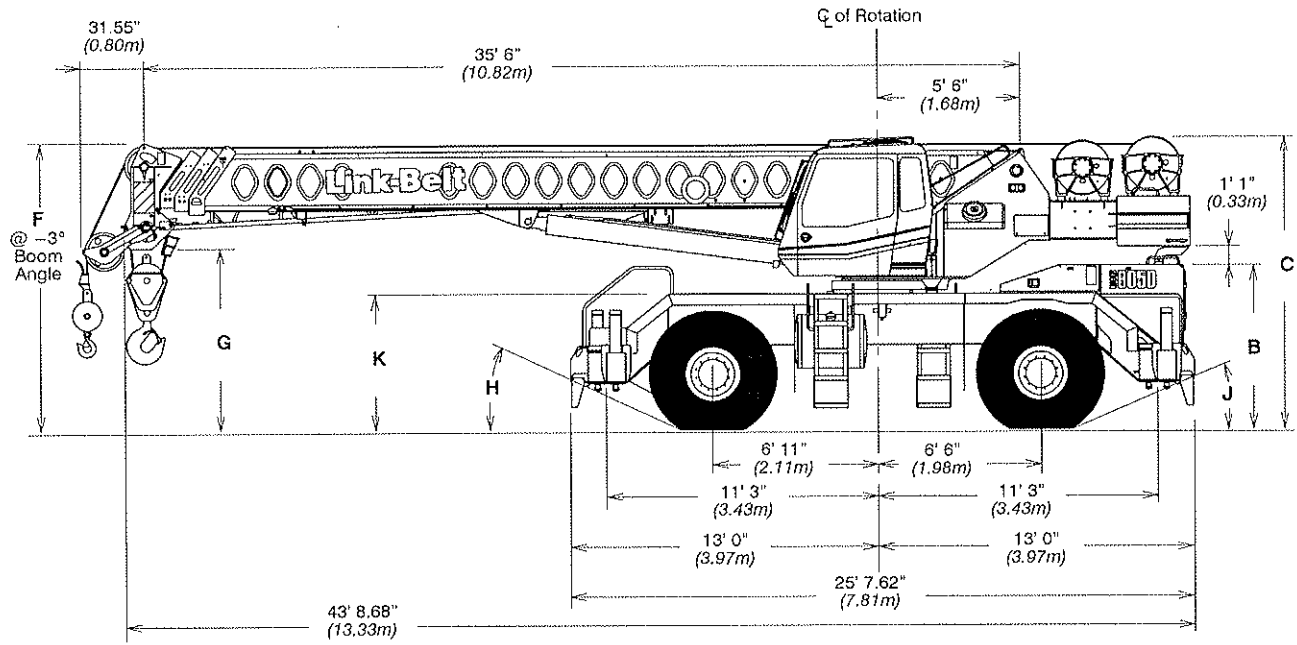

Turning Radius - Front Wheel (4x2) Steering	English	Metric
Wall to wall over carrier	39' 0"	11.9m
Wall to wall over boom	47' 7"	14.5m
Wall to wall over boom attachment	49' 7"	15.1m
Curb to curb	37' 3"	11.4m
Centerline of tire	36' 0"	11.0m

Turning Radius - All Wheel (4x4) Steering	English	Metric
Wall to wall over carrier	23' 4"	7.1m
Wall to wall over boom	34' 0"	10.4m
Wall to wall over boom attachment	35' 6"	10.8m
Curb to curb	21' 4"	6.5m
Centerline of tire	20' 0"	6.1m

Tail Swing	English	Metric
With counterweight	12' 8"	3.9m
Without counterweight	N/A	N/A

General Dimensions	Tire Size			
	23.5 x 25 bias		23.5R25 radial	
	English	Metric	English	Metric
A	10' 3.5"	3.14m	10' 3"	3.12m
B	6' 7.75"	2.03m	6' 9.5"	2.06m
C	11' 11.75"	3.65m	12' 1.5"	3.70m
D	7.75"	0.20m	7"	0.18m
E	10"	0.25m	11.75"	0.30m
F	10' 0.25"	3.05m	10' 2"	3.10m
G	7' 6"	2.29m	7' 7.75"	2.33m
H	24"	--	24.8"	--
J	21"	--	22"	--
K	6' 6.75"	1.69m	6' 8.5"	1.74m
L	8' 3"	2.51m	8' 3"	2.51m

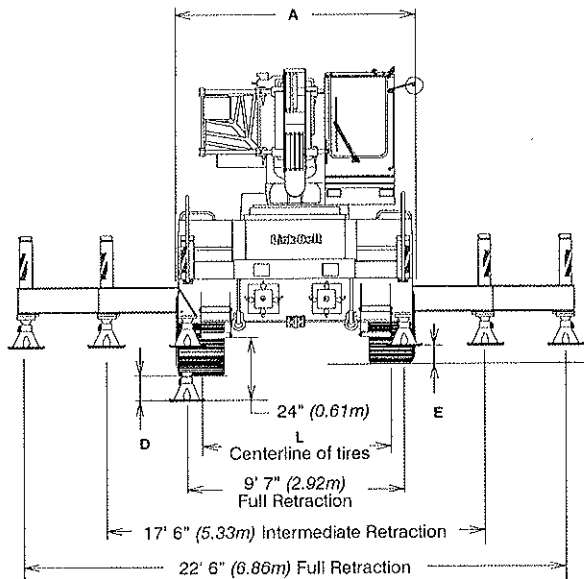

Not To Scale

Working Range Diagram

Working Range Diagram
On Fully Extended Outriggers

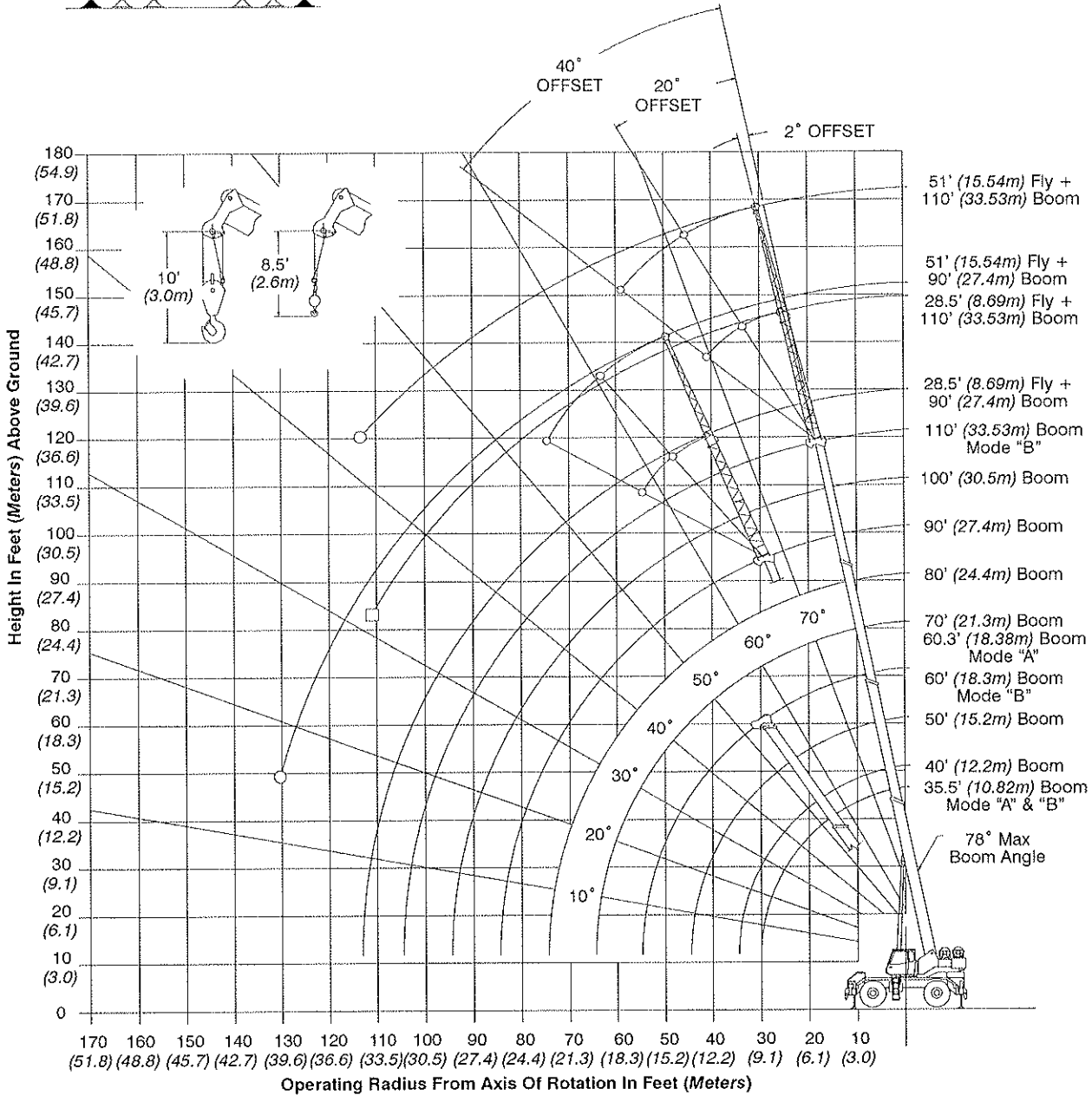

- Denotes Main Boom + 51' (15.5m) Fly – Boom Mode "B"
- Denotes Main Boom + 28.5' (8.7m) Fly – Boom Mode "B"

Main Boom Lift Capacity Charts – Standard

Fully Extended Outriggers – 360° Rotation (All Capacities Are Listed In Pounds)										
Radius (ft)	Boom Length (ft)									Radius (ft)
	35.5	40	50	60/60.3	70	80	90	100	110	
10	100,000	78,400	72,600							10
12	73,900	73,100	65,600	50,900**	37,900					12
15	63,200	63,000	57,500	46,900**	37,900	35,400				15
20	50,300	50,100	47,600	39,200**	37,900	34,700	28,900			20
25	39,000	38,900	38,500	37,900	37,900	34,200	28,200	24,000	19,500	25
30		31,300	31,900	32,300	32,500	30,300	24,800	22,500	19,500	30
35			26,100	26,500	26,700	26,900	22,000	19,900	18,300	35
40			20,800	21,200	21,400	21,500	19,700	17,800	16,400	40
45				17,100	17,300	17,400	17,500	15,900	14,600	45
50				13,900	14,200	14,300	14,400	14,400	13,200	50
55					11,900	12,100	12,200	12,200	12,100	55
60					10,000	10,200	10,300	10,300	10,400	60
65						8,600	8,700	8,800	8,900	65
70						7,300	7,500	7,500	7,600	70
75							6,400	6,500	6,500	75
80							5,400	5,500	5,600	80
85								4,700	4,800	85
90								4,000	4,100	90
95									3,500	95
100									2,900	100

* Special Conditions Or Wire Rope Required
 ** 60.3 A–max Mode

This information is not for crane operation. Operator must refer to the in-cab information for crane operation. Rated lifting capacities shown on fully extended outriggers do not exceed 85% of the tipping loads and on tires do not exceed 75% of the tipping loads.

On Tires – Stationary – Boom Centered Over Front Between Tire Tracks
(All Capacities Are Listed In Pounds)

Radius (ft)	Boom Length (ft)					Radius (ft)
	35.5	40	50	60	70	
10	47,300	47,100				10
12	41,600	41,400				12
15	35,100	35,000	35,800			15
20	27,400	27,300	28,200	28,500		20
25	21,900	21,700	22,900	23,200	23,400	25
30		16,100	16,700	17,100	17,200	30
35			12,600	12,900	13,100	35
40			9,700	10,100	10,300	40
45				7,900	8,200	45
50				6,300	6,500	50
55					5,200	55
60					4,200	60

On Tires – Pick & Carry (Creep) – Boom Centered Over Front
(All Capacities Are Listed In Pounds)

Radius (ft)	Boom Length (ft)					Radius (ft)
	35.5	40	50	60	70	
10	44,100	43,900				10
12	38,400	38,200				12
15	31,800	32,000	32,400			15
20	24,000	24,300	24,700	25,000		20
25	18,600	19,000	19,500	19,800	19,900	25
30		15,100	15,600	15,900	16,100	30
35			12,600	12,900	13,100	35
40			9,700	10,100	10,300	40
45				7,900	8,200	45
50				6,300	6,500	50
55					5,200	55
60					4,200	60

On Tires – Stationary – 360° Rotation
(All Capacities Are Listed In Pounds)

Radius (ft)	Boom Length (ft)					Radius (ft)
	35.5	40	50	60	70	
10	37,200	37,400	37,700			10
12	31,100	31,400	31,800			12
15	24,000	24,400	24,900			15
20	14,500	14,800	15,400	15,700		20
25	9,400	9,800	10,300	10,700	10,900	25
30		6,600	7,100	7,500	7,700	30
35			5,000	5,300	5,500	35
40			3,400	3,700	3,900	40
45				2,500	2,700	45

This information is not for crane operation. Operator must refer to the in-cab information for crane operation. Rated lifting capacities shown on fully extended outriggers do not exceed 85% of the tipping loads and on tires do not exceed 75% of the tipping loads.

Fly Attachment Lift Capacity Charts – Optional

Fully Extended Outriggers – 360° Rotation (All Capacities Are Listed In Pounds)								
110 ft Main Boom Length 2° Fly Offset			110 ft Main Boom Length 20° Fly Offset			110 ft Main Boom Length 40° Fly Offset		
Radius (ft)	Fly Length (ft)		Radius (ft)	Fly Length (ft)		Radius (ft)	Fly Length (ft)	
	28.5	51		28.5	51		28.5	51
35	9,400		45	9,500		50	7,500	
40	9,400		50	9,100		55	7,300	
45	9,400	6,200	55	8,400		60	7,100	
50	9,400	6,200	60	7,800	4,800	65	6,900	
55	9,200	6,200	65	7,300	4,600	70	6,500	
60	8,500	6,200	70	6,800	4,400	75	6,100	3,400
65	7,900	6,000	75	6,400	4,300	80	5,800	3,400
70	7,300	5,700	80	6,000	4,100	85	5,500	3,300
75	6,800	5,300	85	5,700	4,000	90	5,200	3,200
80	6,200	4,900	90	5,000	3,800	95	4,600	3,200
85	5,300	4,600	95	4,300	3,700	100	3,900	3,100
90	4,600	4,300	100	3,700	3,500	105	3,300	3,100
95	4,000	4,000	105	3,200	3,300	110	2,800	3,000
100	3,500	3,800	110	2,700	3,200	115		2,900
105	3,000	3,500	115	2,300	3,000	120		2,800
110	2,500	3,000	120		2,600	125		2,400
115	2,100	2,600	125		2,200	130		2,000
120		2,200	130		1,900			

This information is not for crane operation. Operator must refer to the in-cab information for crane operation. Rated lifting capacities shown on fully extended outriggers do not exceed 85% of the tipping loads and on tires do not exceed 75% of the tipping loads.